

VSR – Vertical Stack Rail

PLYMOVENT®
VEHICLE EXHAUST REMOVAL SYSTEMS

The vertical stack rail requires no operator intervention

The VSR is the solution to vehicles that have top exhaust and have to move through a service bay.



We recommend the VSR for emergency response vehicles with top exhaust such as airport crash rescue vehicles, heavy rescue and transit bus operation. The VSR can be set up for back-in or drive-through configurations. It will also handle multiple vehicles in tandem and can be retrofitted into any length of building.

Features and Benefits

- Floating suspension
- Air volumes as high as 2380 m³/h/1400 CFM
- Compact clearance to vehicle
- Adjustable height stack capture
- Fits any vehicle stack
- Operator free operation
- One-piece aluminium rail



Method of Operation

An automatic, mechanical exhaust gas extraction system, specially designed for fire and rescue vehicles with top exhaust pipes. The system is used to remove the poisonous petrol and diesel gas fumes direct at the emission source, the exhaust pipe. When the vehicles reverse or drive in to the fire station, a "catcher" box picks up on the special tapered connection on the vertical exhaust pipe, aligning itself on the aluminium profile both upwards

and sideways. As the vehicles continue into the station, the exhaust pipe glides along the rubber sealed profile until the vehicle is parked. All of the poisonous exhaust gases being contained in the profile under vacuum, to be extracted by a fan to the outside of the building. Upon a call-out, the vehicles glide out of the profile in a similar way, and the track resumes it's natural position by the use of mounting springs.



These pictures show the worlds largest crash rescue vehicle, listed in the Guinness Book of Records. The vehicle is in service at the rescue station at Munich International Airport, Germany.



Advantages

- A fully automatic system.
- Expandable system to almost any length.
- Adapter cone designed for both empty and loaded vehicles.
- 300 mm/11.8" lateral movement to either side.
- Flexible duct connection.
- Sealing rubber lips; negative pressure.
- Automatic return to position after lateral movement.
- Adjustable support legs.
- Security wire, fail safe.
- Suitable for existing fire stations and new design build stations.

The system allows both back in and drive through operations

- The "catcher" box will pick up on the special tapered connection on the vertical exhaust pipe, aligning itself on the aluminium profile both upwards and sideways.

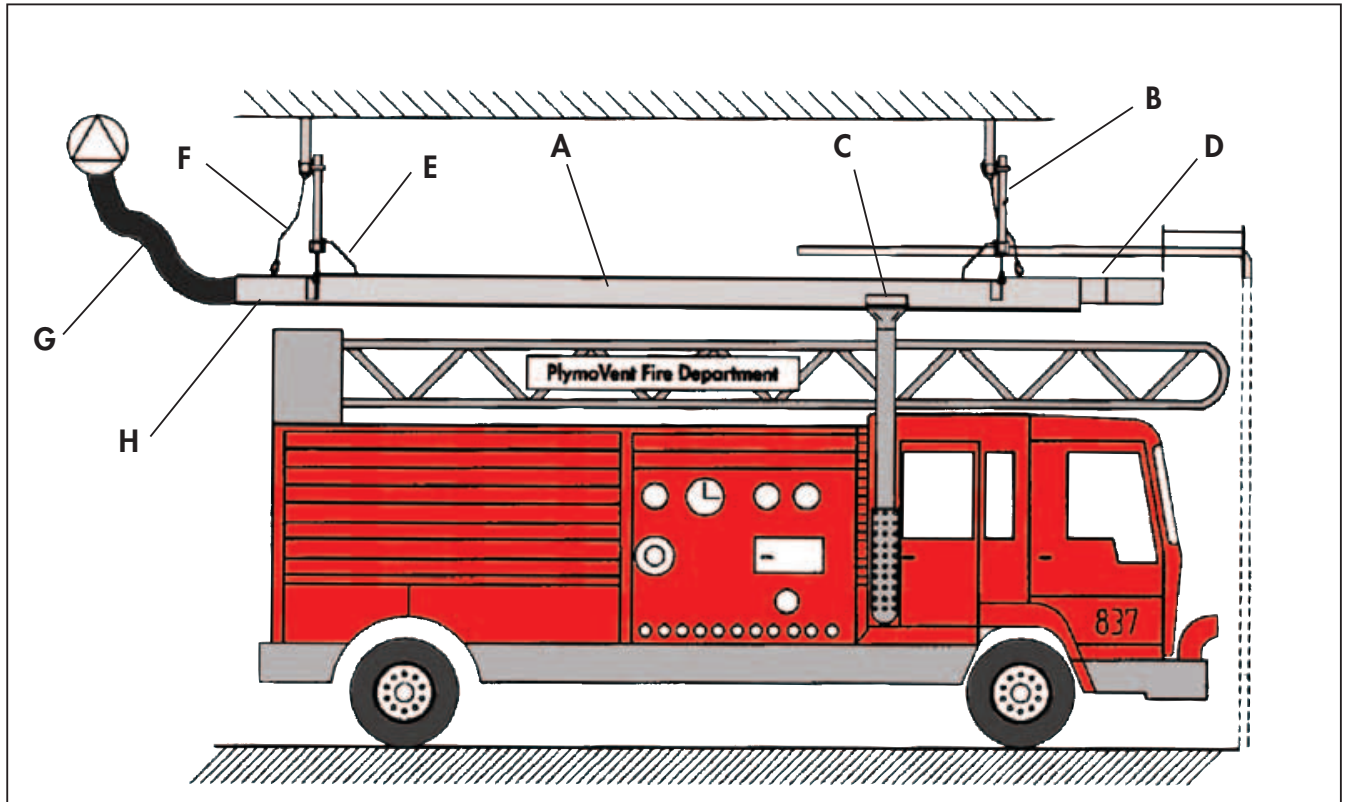

- | | | | |
|----------|----------------|----------|-------------------------------|
| A | Aluminium rail | E | Centering spring |
| B | Support leg | F | Safety wire |
| C | Stack adapter | G | Flexible duct connection hose |
| D | Catcher | H | Adjustable damper |

Product Description

The VSR System consists of a durable rectangular aluminium profile with a section area of 280 cm²/43.4 in². The bottom side of the rail is an open area sealed with rubber lips. The rail is hung on two (2) bearing loaded trolleys at each support. The profile is connected to the duct system by a Ø 160 mm/6.25" hose. The front opening of the profile has a "V" formed catcher to accommodate the stack adapter, mounted on the vertical exhaust pipe. The stack adapter converts the round shape of the exhaust pipe to be flat without changing the section area. As the returning vehicle enters the station the catcher and the profile align themselves to the exhaust pipe position. This side movement is crea-

ted via the bearing loaded runners sliding in the Boxloc track of the support leg. The Boxloc hangs in two adjustable vertical legs mounted to the general roof structure. The support legs allow the VSR to have a lateral movement from two separate points of 300 mm/11.8" to either side. As the fire engine drives out of the station the exhaust pipe glides along the rail, between the rubber sealing, up to the point where the vehicle exits of the station. A spring is connected between the support legs and aluminium rail to move the rail into its central rest position.

The VSR System is equipped with safety wires capable of carrying the complete system.

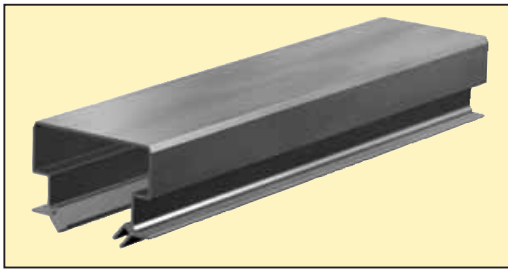

Extraction Rail, 5,8 m/19 ft, or ordered by the meter.

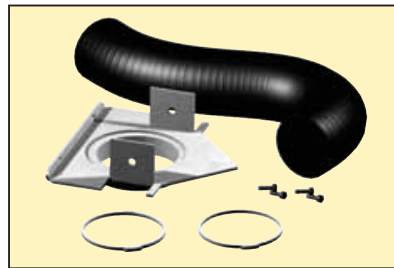

Back-In Connection with end connection, flexible hose 1,3 m/4.3 ft and hose clamps.



Drive-through Connection with top connection, flexible hose 3,1 m/10.2 ft and hose clamps.

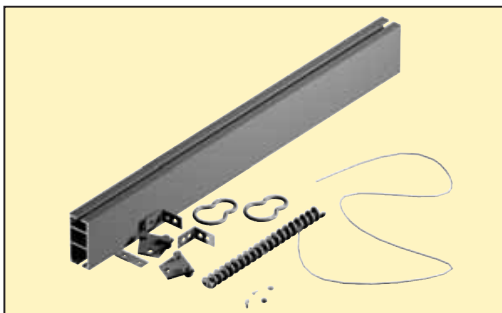

VSR-Kit, consisting of suspension profile, 2 suspension brackets and trolleys, 1 centering spring, safety wire, trolley stops and hardware for one suspension point.

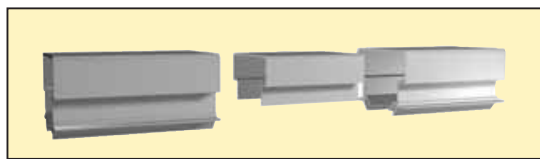

Extraction Rail Splice, for connecting rails.



Extraction Rail Rubber Seal, low friction.

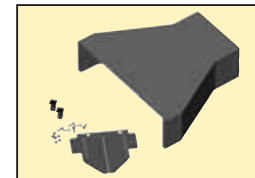

VSR-Catcher, including gate damper.

TECHNICAL DATA

Prod no	Extraction Rail, length, m / ft	Rail slice	Rail Rubber Seal, m / ft	Exhaust Pipe Catcher	Suspension Kit	Back-in Connection	Drive-through Connection
VSR-6	5,8 / 19.0	—	12 / 38.4	1 pc	2 pcs	1 pc	—
VSR-9	8,8 / 28.8	1 pc	18 / 57.6	1 pc	3 pcs	1 pc	—
VSR-12	11,6 / 38.0	1 pc	24 / 76.8	1 pc	3 pcs	1 pc	—
VSR-12-D	11,6 / 38.0	1 pc	24 / 76.8	2 pcs	3 pcs	—	1 pc
VSR-15	14,6 / 47.8	2 pcs	30 / 96.0	1 pc	3 pcs	1 pc	—
VSR-15-D	14,6 / 47.8	2 pcs	30 / 96.0	2 pcs	3 pcs	—	1 pc
VSR-18	17,4 / 57.0	2 pcs	36 / 115.2	1 pc	4 pcs	1 pc	—
VSR-18-D	17,4 / 57.0	2 pcs	36 / 115.2	2 pcs	4 pcs	—	1 pc
VSR-21	20,4 / 66.8	3 pcs	42 / 134.4	1 pc	4 pcs	1 pc	1 pc
VSR-21-D	20,4 / 66.8	3 pcs	42 / 134.4	2 pcs	4 pcs	—	2 pcs
VSR-24	23,2 / 76.0	3 pcs	48 / 153.6	1 pc	5 pcs	1 pc	1 pc
VSR-24-D	23,2 / 76.0	3 pcs	48 / 153.6	2 pcs	5 pcs	—	2 pcs

Fan and fan control device to be added individually depending on application.

Stack adapter

Prod. no **Description**

FBC-83 Stack adapter cone in stainless steel, Ø 83 mm/3.3"

FBC-93 Stack adapter cone in stainless steel, Ø 93 mm/3.7"

FBC-113 Stack adapter cone in stainless steel, Ø 113 mm/4.5"

Stack adapter, to convert the shape of vertical exhaust pipes to fit the rail.

