

ULTRAFLEX-4/LOWCEILING

ULTRAFLEXIBLE EXTRACTION ARM

The UltraFlex-4/LowCeiling is a wall-mounted flexible extraction arm with a rotatable hood *RotaHood*. Incorporated into the hood is a throttle valve that can be fully opened, partially opened or completely closed to control airflow at hood opening. The arm features a focus extraction spoiler, which directs the air into the hood.

The arm is provided with the *BalanceWheel* spring balance system for ultra-light, user friendly positioning of the arm.

The UltraFlex-4/LowCeiling is suitable for stationary welding fume extraction systems only. It is particularly suitable to be mounted under low ceilings (min. 2500 mm/100 in.).



APPLICATIONS

The UltraFlex-4/LowCeiling is intended to be used for the following applications:

- MIG-MAG/GMAW welding
- TIG welding
- FCAW welding
- stick/MMAW welding



Do **not** use the UltraFlex-4/LowCeiling for the following applications or in the following circumstances:

- arc-air gouging
- aluminium laser cutting
- extraction of aggressive fumes and gases (e.g. from acids, from alkaline, from soldering paste containing lithium)
- extraction of hot gases (more than 45°C/113°F continuously)
- grinding aluminum and magnesium
- flame spraying
- extraction of cement, saw dust, wood dust etc.
- sucking cigarettes, cigars, oiled tissues and other burning particles, objects and acids
- explosive environments or explosive substances/gases



SPECIFICATIONS

Physical dimensions and properties

Arm length	4 m (13 ft)
Diameter	203 mm (8 in.)
Material:	
• tubes and hood	• polypropylene copolymere with UV stabilization
• hoses	• PVC with metal springs
• throat	• ABS
• handle, rim and grid	• nylon, glass fibre reinforced
Max. temperature (continuously):	
• tubes and hood	• 80°C (176°F)
• hoses	• 80°C (176°F)
• throat	• 80°C (176°F)
• handle, rim and grid	• 95°C (203°F)
Colour:	
• tubes and hood	• yellow RAL 1028
• hoses	• grey RAL 7024
Weight (net)	17 kg (37.5 lbs)

Performance

Airflow	max. 1600 m ³ /h (942 CFM)
Ambient conditions	
Operating temperature:	
• min.	• 5°C (41°F)
• nom.	• 20°C (68°F)
• max.	• 45°C (113°F)
Max. relative humidity	80%
Outdoor use allowed	no
Storage conditions	• 5-45°C (41-113°F) • relative humidity max. 80%
Product combinations	
TNB	wall bracket
TNB + FAN-28	wall bracket + fan
TNB + FAN-42	
Available options	
WL	working light
WL+AST	working light + automatic start/stop
Scope of supply	
Extraction arm - Hood - Rotating hinge (flange, collar, spring) - Hose 50 cm - Hose 65 cm - Hose 115 cm - Bush (5) - Hardware	
Order information	
Article number	7925230090
Number/package	1
Shipping data	
Gross weight	23 kg (50.5 lbs)
Packing dimensions	210 x 30 x 45 cm (82.7 x 11.8 x 17.7 in.)
Max. number/pallet	6
Harmonized Tariff Code	8421.9900.99
Country of origin	the Netherlands

■ Approvals/certificates



EU Directive 2002/95/EC
(RoHS) (valid as of July 2006)

FEATURES

BalanceWheel balance system

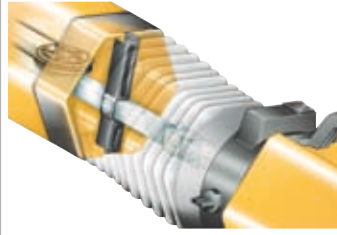

RotaHood 360° rotatable hood



REACH

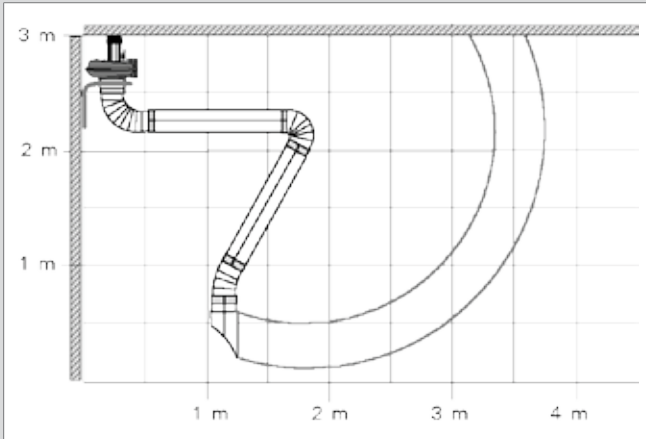

UltraFlex-4/LowCeiling with fan in normal position

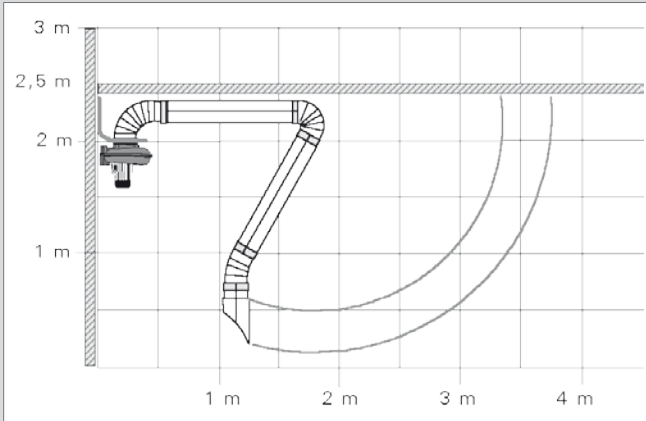

UltraFlex-4/LowCeiling with fan mounted upside down

PRESSURE DROP

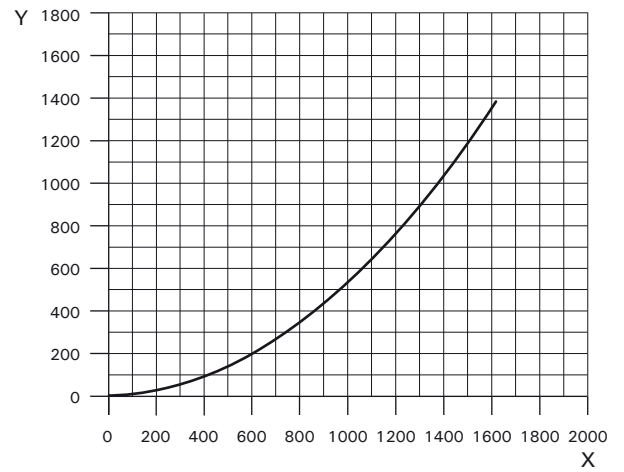

X = Airflow (m³/h)
Y = Static pressure (Pa)

MOUNTING MEASUREMENTS

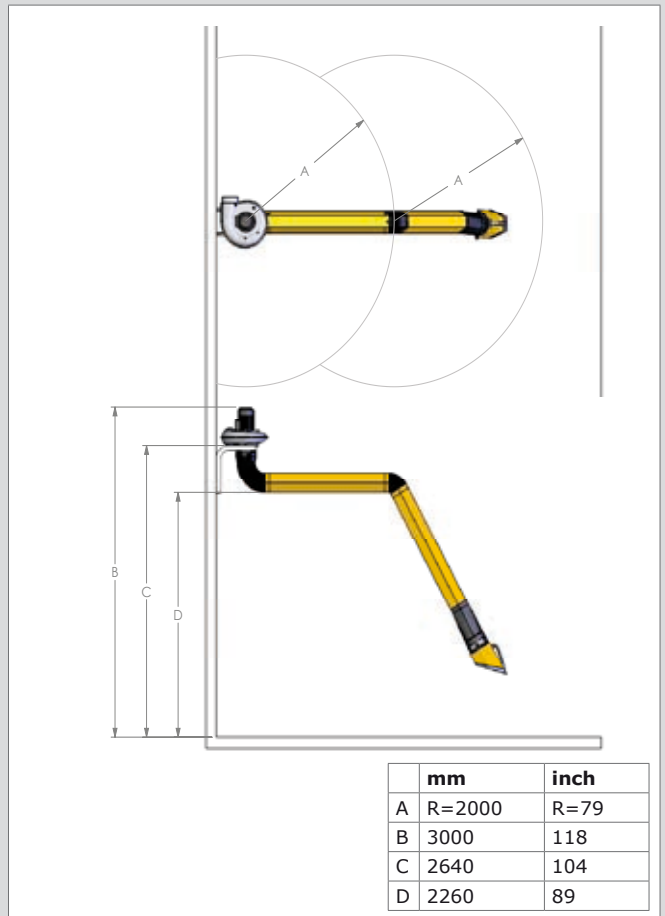

UltraFlex-4/LowCeiling + TNB + FAN-28

Product type	UltraFlex-4/ LowCeiling
Article no.	7925230090
Product category	extraction arms/hoses
Version	160610/C

Always check the latest version on www.plymovent.com